

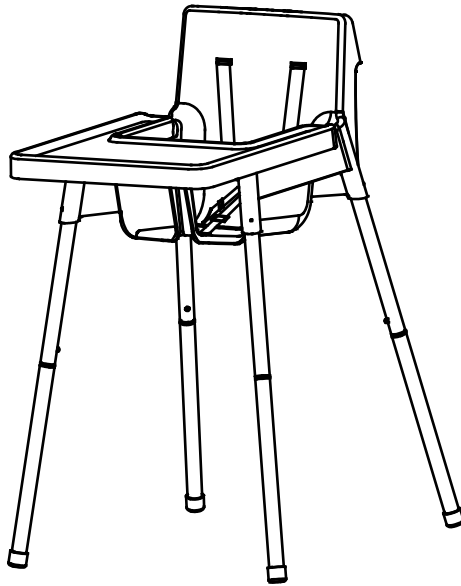

Quadro High Chair

Owner's Manual



IMPORTANT! KEEP FOR FUTURE REFERENCE
Read all instructions BEFORE assembly and USE of product

Note: Drawings in the manual are for illustration purpose only. Actual product may vary . The manufacturer reserves the right to change any specification of features without prior notice.

1 Welcome

The Quadro High chair is carefully designed for baby's safety and features a large removable tray and wipe clean seat with five point harness. Suitable for children who are able to sit up unaided (6-36 months). Complies with AS 4684-2009.

To ensure safe, trouble free use, please take a little time to read the important safety notes below and the following instructions.

2 Safety Notes

WARNING!

- FOLLOW THE MANUFACTURER'S INSTRUCTIONS.
- DO NOT LEAVE CHILDREN UNATTENDED.
- THE HARNESS MUST ALWAYS BE USED AND CORRECTLY FITTED—MOST INJURIES FROM HIGH CHAIRS ARE CAUSED BY FALLS.
- POSITION THE HIGH CHAIR AWAY FROM SOLID STRUCTURES AND BENCHES TO AVOID INJURIES CAUSED BY FALLS AND BY ACCESS TO DANGEROUS ITEMS.
- Adult assembly required.
- Do not use the high chair unless all components are correctly fitted and adjusted
- Use only on a flat, even and horizontal floor. Do not elevate the high chair on any structure or table.
- To reduce the risk of injury, position the high chair away from furniture, walls, hot surfaces and liquids, window covering cords, and electrical cords and position the high chair away from furniture when the chair is not being used at a table with a tray removed.
- Be aware of the risk of open fire and other sources of strong heat, such as electric bar fires, gas fires etc. in the vicinity of the high chair.
- Do not use the high chair until the child can sit up unaided.
- This high chair should be used in an upright position only by children capable of reliably and consistently sitting upright.
- This high chair is designed to be used by a child up to 3 years of age. Maximum weight 18kg.
- Do not use this high chair for more than one child at a time and do not leave other children playing unattended near the high chair.
- If the high chair is not working correctly, do not use and seek repair.
- Regularly inspect your high chair. Discontinue use if any part is broken, torn or missing.

3 Parts List

Please retain all packaging until you are certain no parts are missing.
After assembly, please dispose of all packaging carefully.

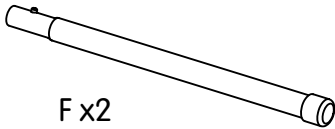
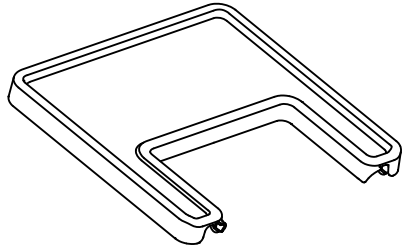
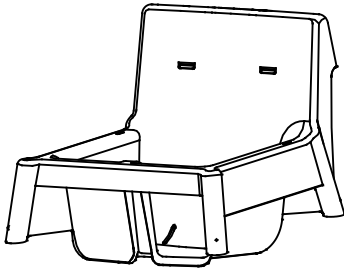

F x2
(F=Front)

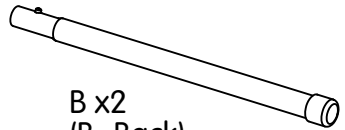

B x2
(B=Back)

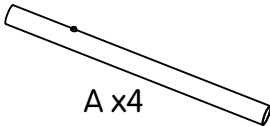

A x4

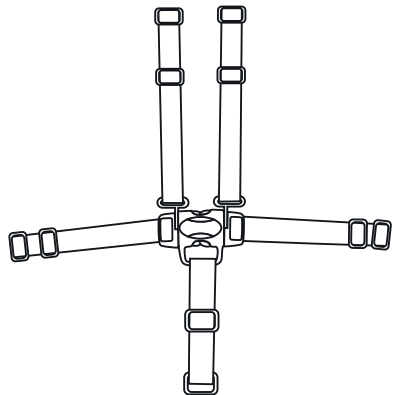

4 Legs Assembly

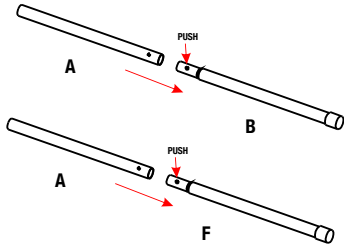

Depress spring button and connect legs together, ensuring that the button clicks through the corresponding hole.

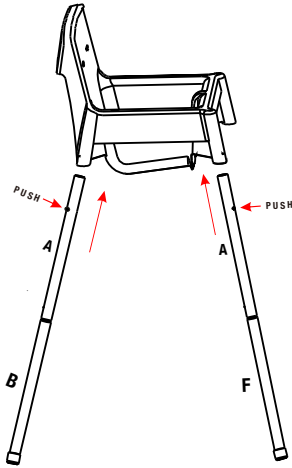

Once assembled, attach legs to chair body, taking care that front and back legs are in the correct location. Ensuring that the button clicks through the corresponding hole.



High Chair seat body with four legs assembled.

5 Tray Assembly

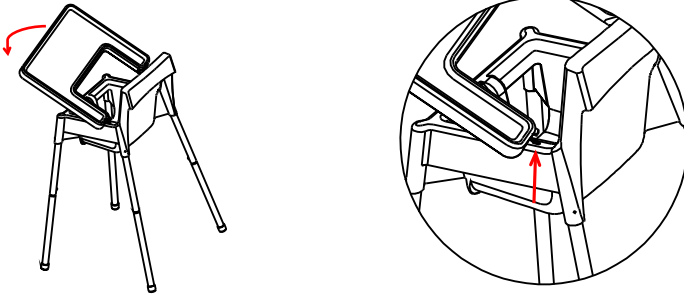

Insert the hooks on the tray into the corresponding slots on the armrests.
Gently press down until the tray clicks into place.

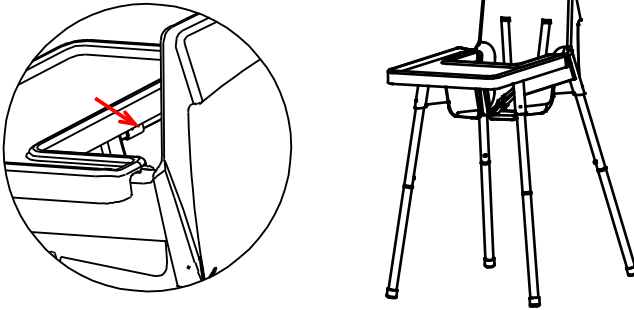

WARNING: Always ensure that the tray is locked correctly before use.

6 To Remove Tray

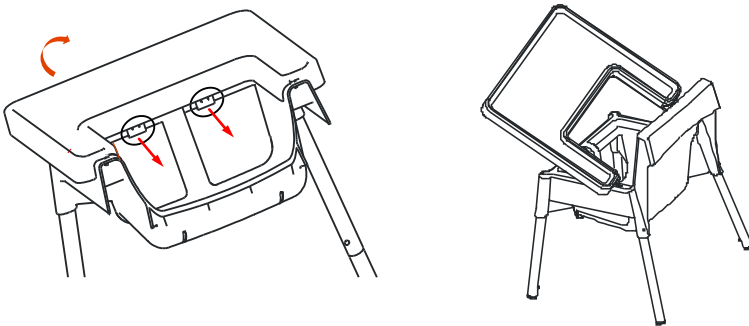

Using both hands, pull and lift the clips attaching the tray to the chair at the leg opening. The tray can then be lifted off the chair body.

7 Safety Harness

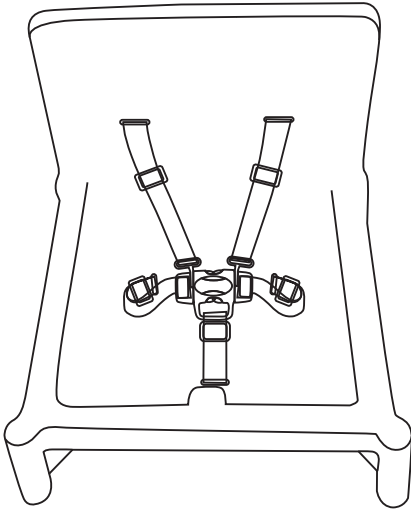

A five-point safety harness is provided to restrain your child and should always be worn.

The harness comes fitted to the seat. Ensure the waist straps, shoulder straps and crotch strap are fed through the slots in the seat unit before use.

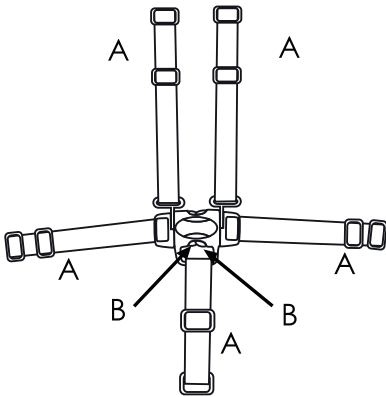

Sliding adjusters, **A**, are fitted and should be carefully adjusted so the harness fits your child comfortably.

To fasten the harness push the side pieces into the centre buckle.

To release, press parts **B** and remove from the buckle.

WARNING: USE THIS HARNESS AT ALL TIMES.

8 Disassembly

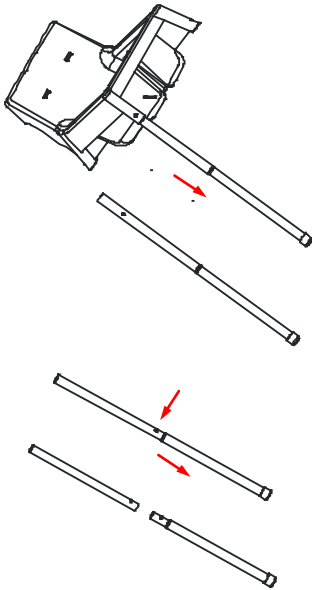

Depress spring buttons to remove legs from chair body.

Depress spring buttons and pull apart leg tubes.

9 Care and Maintenance

- Wipe spilled food off the high chair as soon as possible as some types of food may cause staining. Wipe clean with a cloth dampened in a mild cleaner. Wipe dry with a soft, clean cloth. Do not use bleach.
- Regularly check the high chair, particularly the harness for wear and discontinue use if damaged.



© Kmart Australia Limited